

SOLENOID VALVES

SV10-21 Poppet, 2-Way, Normally Open

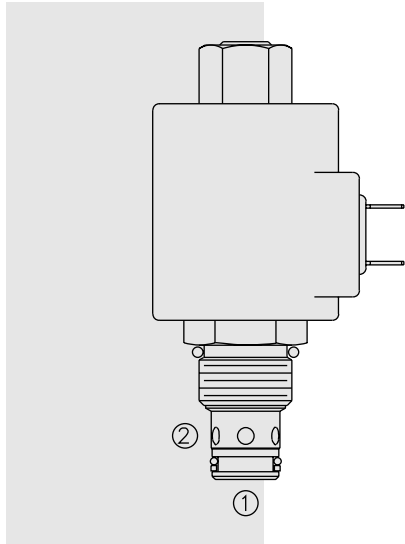

DESCRIPTION

A solenoid-operated, 2-way, piloted, poppet-type, normally open, screw-in, hydraulic cartridge valve designed for low leakage in load-holding applications.

OPERATION

When de-energized, the SV10-21 allows flow from ② to ①. Flow from ① to ② is severely restricted in this mode. If the ① to ② path is required, see model SV10-23, page 1.053.1.

When energized, the valve's poppet closes on its seat, blocking flow in the ② to ① direction. In this mode the cartridge will allow ① to ② flow after overcoming the solenoid force (requires 3.4 to 10.3 bar [50 to 150 psi]).

Operation of the Manual Override Option: To override, push and hold override button.

FEATURES

- Continuous duty-rated solenoid.
- Hardened seat for long life and low leakage.
- Optional coil voltages and terminations.
- Efficient wet-armature construction.
- Cartridges are voltage interchangeable.
- Unitized, molded coil design.
- Industry common cavity.
- Manual override option.
- Optional waterproof E-Coils rated up to IP69K.

SYMBOLS

USASI:

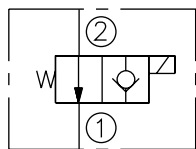

ISO:

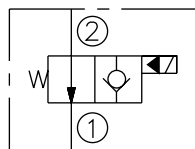

PERFORMANCE (Cartridge Only)

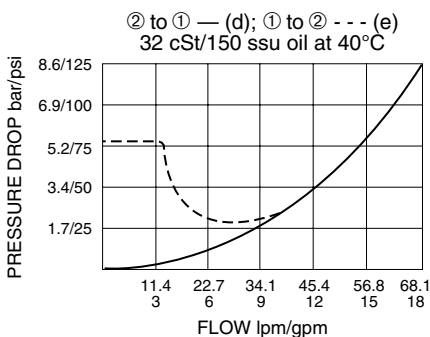

RATINGS

Operating Pressure: 207 bar (3000 psi)

Proof Pressure: 345 bar (5000 psi)

Flow: See Performance Chart

Internal Leakage: 0.15 cc/minute (3 drops/minute) max. at 207 bar (3000 psi)

Temperature: -40 to 120°C with standard Buna seals

Coil Duty Rating: Continuous from 85% to 115% of nominal voltage

Response Time: First indication of change of state with 100% voltage supplied at 80% of nominal flow rating: Energized: 80 msec.; De-energized: 30 msec.

Initial Coil Current Draw at 20°C: Standard Coil: 1.67 amps at 12 VDC; 0.18 amps at 115 VAC (full wave rectified). E-Coil: 2.0 amps at 12 VDC; 1.0 amps at 24 VDC

Minimum Pull-in Voltage: 85% of nominal at 207 bar (3000 psi)

Filtration: See page 9.010.1

Fluids: Mineral-based or synthetics with lubricating properties at viscosities of 7.4 to 420 cSt (50 to 2000 ssu)

Installation: No restrictions; See page 9.020.1

Cavity: VC10-2; See page 9.110.1

Cavity Tool: CT10-2XX; See page 8.600.1

Seal Kit: SK10-2X-T; See page 8.650.1

Coil Nut: Part No. 7004420;

For E-coils manufactured prior to 1-1-04, see page 3.400.1 for coil nut info.

SV10-21

DIMENSIONS

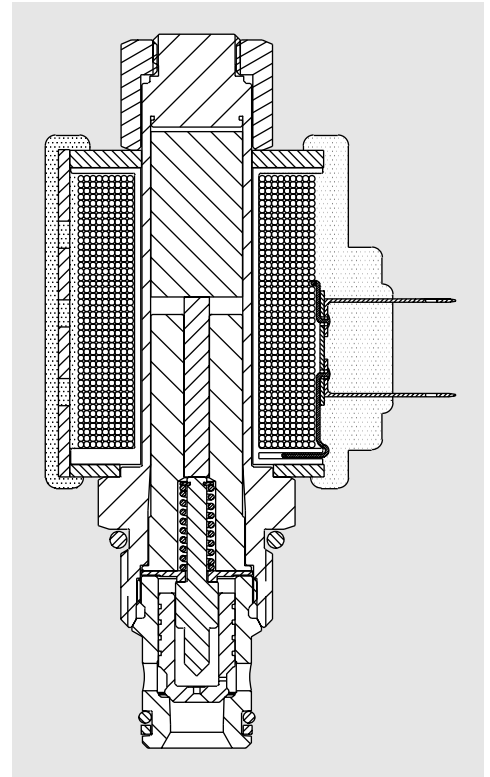
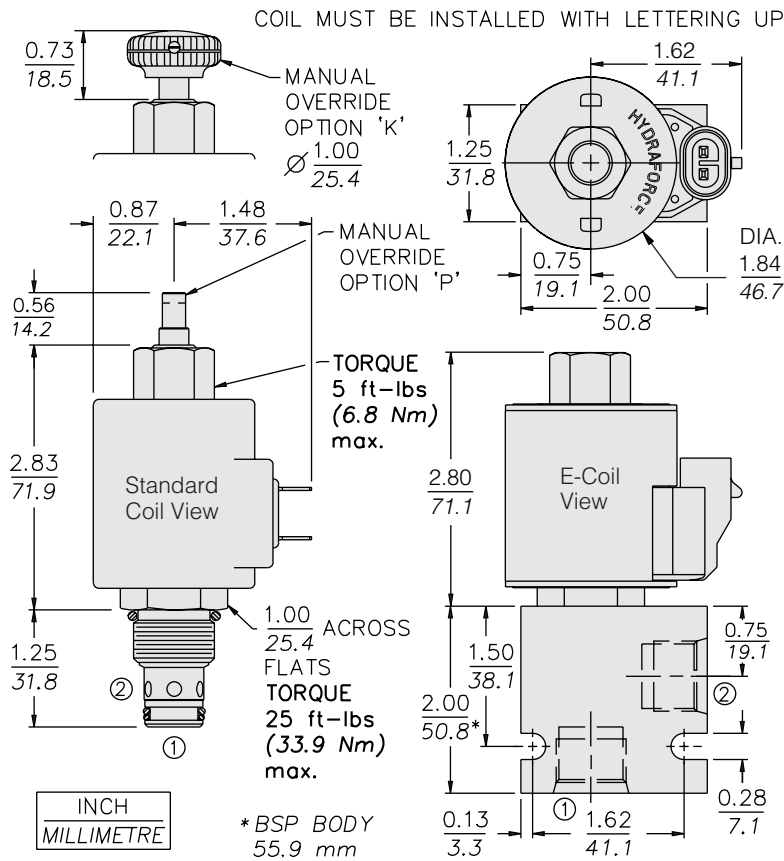

MATERIALS

Cartridge: Weight: 0.16 kg. (0.35 lbs.); Steel with hardened work surfaces. Zinc-plated exposed surfaces. Buna N O-rings and polyester elastomer back-up standard.

Standard Ported Body: Weight: 0.16 kg. (0.35 lbs.); Anodized high-strength 6061 T6 aluminum alloy, rated to 240 bar (3500 psi); See page 8.010.1. Ductile iron and steel bodies available; consult factory.

Standard Coil: Weight: 0.27 kg. (0.60 lbs.); Unitized thermoplastic encapsulated, Class H high temperature magnetwire; See page 3.200.1.

E-Coil: Weight: 0.41 kg. (0.9 lbs.); Fully encapsulated with rugged external metal shell; Rated up to IP69K with integral connectors; **Note: See page 3.400.1 for all E-Coil retrofit applications.**

TO ORDER

SV10-21

Option	None (Blank)				
	Screen	S			
	Manual Override without Knob	P			
	Manual Override with Knob	K			
Porting	Cartridge Only	0			
	SAE 6	6T			
	SAE 8	8T			
	1/4 in. BSP*	2B			
	3/8 in. BSP*	3B			
	1/2 in. BSP*	4B			
	*BSP Body; U.K. Mfr. Only				
Seals	Buna N (Std.)	N			
	Fluorocarbon	V			
			Voltage Std. Coil		Termination (VDC) Std. Coil
			0 Less Coil**		DS Dual Spades
			10 10 VDC†		DG DIN 43650
			12 12 VDC		DL Leadwires (2)
			24 24 VDC		DL/W Leads w/Weatherpak® Connectors
			36 36 VDC		DR Deutsch DT04-2P
			48 48 VDC		
			24 24 VAC		Termination (VAC) Std. Coil
			115 115 VAC		AG DIN 43650
			230 230 VAC		AP 1/2 in. Conduit
			**Includes Std. Coil Nut		Termination (VDC) E-Coil
			† DS, DW or DL terminations only		ER Deutsch DT04-2P (IP69K Rated)
			E-Coil		EY Metri-Pack® 150 (IP69K Rated)
			10 10 VDC		
			12 12 VDC		
			20 20 VDC		
			24 24 VDC		

Coils with internal diode are available. Consult factory.